

Columbia Weather Systems Weather Display™

User Manual

Version 3.11

All specifications subject to change without notice.

Printed in U. S. A.

Weather Display User Manual

Catalog Number: 81637

Version 3.11

Printed in U.S.A.

Copyright

© Copyright 2003-2007, Columbia Weather Systems, Inc. All Rights Reserved

Proprietary Notice

Capricorn 2000, Capricorn 2000EX, Pegasus, Pegasus EX, Orion and Orion LX Weather Stations are trademarks of Columbia Weather Systems, Inc. The information and drawings contained herein are the sole property of Columbia Weather Systems, Inc. Use of this publication is reserved exclusively for customers of Columbia Weather Systems, Inc. and their personnel. Reproduction of this material is forbidden without the express written consent of Columbia Weather Systems, Inc.

Company Address

Columbia Weather Systems, Inc.
2240 NE Griffin Oaks Street, Suite 100
Hillsboro, OR 97124-6463

Telephone: (503) 629-0887

Fax: (503) 629-0898

Web Site: <http://www.columbiaweather.com>

Email: info@columbiaweather.com

Table of Contents

TABLE OF CONTENTS	5
WELCOME.....	9
SHIPPING DAMAGE.....	11
INTRODUCTION	13
<i>Features and Capabilities.....</i>	<i>13</i>
PHYSICAL DESCRIPTION	15
<i>Desktop Chassis.....</i>	<i>15</i>
<i>Panel Mount.....</i>	<i>16</i>
<i>19" Rack Mount</i>	<i>17</i>
INSTALLATION.....	19
LOCATION CONSIDERATIONS.....	19
BASE INSTALLATION	19
POWER CONNECTION.....	20
RS-232 CONNECTION	20
<i>Capricorn 2000/2000EX, Direct RS-232</i>	<i>20</i>
<i>Pegasus/Wireless</i>	<i>20</i>
<i>Orion Weather Station, Direct RS-232</i>	<i>21</i>
<i>Orion LX Weather Station, Direct RS-232.....</i>	<i>21</i>
ANGLE ADJUSTMENT.....	22
CONTRAST ADJUSTMENT.....	22
PANEL MOUNT INSTALLATION	23
RACK MOUNT INSTALLATION.....	23
OPERATION	25
INITIALIZATION.....	25
MAIN SCREEN.....	26
<i>Date and Time.....</i>	<i>26</i>
<i>Temperature.....</i>	<i>26</i>
<i>Relative Humidity/Dew Point.....</i>	<i>26</i>
<i>Barometric Pressure</i>	<i>27</i>
<i>Barometric Pressure Trend.....</i>	<i>27</i>
<i>Rain for the Day.....</i>	<i>27</i>
<i>Density Altitude.....</i>	<i>27</i>
<i>Wind Speed.....</i>	<i>28</i>
<i>Wind Direction.....</i>	<i>28</i>
TEMPERATURE (TEMP) SCREEN.....	29
<i>Temperature.....</i>	<i>29</i>

<i>Temperature 2 through 4</i>	29
<i>Wind Chill</i>	30
<i>Heat Index</i>	30
<i>Dew Point/Humidity</i>	30
<i>Channel X1</i>	30
MOISTURE (MOIST) SCREEN	31
<i>Rain for the Day</i>	31
<i>Rain for the Week</i>	31
<i>Rain for the Month</i>	31
<i>Rain for the Year</i>	32
<i>Rainfall Rate</i>	32
<i>Leaf Wetness</i>	32
<i>Channel X2</i>	32
MIN/MAX SCREEN	33
TRENDS SCREEN	34
UNITS SCREEN	36
CONFIG. SCREEN	37
<i>Contrast</i>	37
<i>Beeper</i>	37
<i>Wind Direction Offset</i>	37
<i>Date/Time</i>	38
<i>Calibration/Offsets</i>	38
<i>Temperature Offsets</i>	39
<i>Pressure Offset</i>	39
<i>Altitude</i>	39
<i>Rain Offset</i>	39
<i>Keypad</i>	40
<i>Advanced Settings</i>	41
SCREEN SAVER	43
MAINTENANCE	45
TROUBLESHOOTING	47
<i>Communication Indicator</i>	47
<i>Incorrect Temperature Readings</i>	47
<i>Trend Chart Not Updating</i>	47
<i>Backlight Will Not Turn On</i>	47
USER SUPPORT INFORMATION	49
LIMITED WARRANTY	49
<i>Exclusions</i>	49
RETURN FOR REPAIR PROCEDURE	50
REFERENCE	53
GLOSSARY	53
<i>Aspirating Radiation Shield</i>	53
<i>Barometric Pressure</i>	53

<i>Celsius Temperature Scale</i>	53
<i>Dew Point</i>	53
<i>Density Altitude</i>	53
<i>Fahrenheit Temperature Scale</i>	53
<i>Global Radiation</i>	54
<i>Heat Index</i>	54
<i>Pyranometer</i>	54
<i>Relative Humidity</i>	54
<i>Sea Level Pressure</i>	54
<i>Soil Moisture</i>	54
<i>Solar Radiation</i>	54
<i>Wind Chill</i>	54
UNIT CONVERSION	55
<i>Speed</i>	55
<i>Temperature</i>	55
<i>Distance</i>	55
<i>Pressure</i>	55
<i>Solar Radiation</i>	55
TABLES AND FORMULAS.....	56
<i>Wind Chill Chart</i>	56
<i>Wind Chill Equation</i>	57
<i>Heat Index</i>	58
<i>Dew Point</i>	59

Welcome

Welcome to the Columbia Weather Systems family of users and congratulations on your purchase of the Weather Display console.

The Weather Display is a precision instrument that requires proper installation and handling.

Please read this manual completely prior to installation.

Shipping Damage

BEFORE YOU READ ANY FURTHER, please inspect all system components for obvious damage. The Weather Display is a sensitive electronic instrument and can be damaged by rough handling. Your unit was packaged to minimize the possibility of damage in transit. Therefore, we recommend that you save the shipping container for any future shipment of your Weather Display.

NOTE: DO NOT RETURN THE INSTRUMENT TO COLUMBIA WEATHER SYSTEMS until the following steps are completed. Failure to follow this request will jeopardize your claim.

1. Open the container and inspect the contents. Do not throw away the container or any damaged parts. Try to keep items in the same condition as originally received.
2. Notify the transport company immediately in writing, preferably by facsimile, about the shipping damage.
3. Wait for the transport company's representative to inspect the shipment personally.
4. After inspection, request permission from Columbia Weather Systems for return of the damaged instrument by calling (503) 629-0887.
5. Return approved items to us at the following address:
Columbia Weather Systems, Inc.
2240 NE Griffin Oaks Street, Suite 100
Hillsboro, OR 97124
6. After return authorization is issued and we receive the instrument, an estimate of the cost of repair will be sent to you for submission to the transport company as a claim.

Introduction

The Weather Display uses an “intelligent” touch screen display. With its programmable microprocessor and abundant memory, the Weather Display can display weather information, perform complex computations and store relatively large amounts of weather data.

The Weather Display features a graphic LCD (320 x 240 pixels) monitor with a white background and blue text and graphics. The screens are designed to be viewed clearly from a distance.

Features and Capabilities

- Display date and time
- Display the values of all the sensors from any weather station from Columbia Weather Systems depending on the factory set software configuration.
- Calculate wind chill, dew point, heat index, density altitude and rain rate
- Display the barometric pressure trend
- Display the rain for today, the week, the month and the year
- Display user defined wind speed average and wind speed gust
- Display min/max values and time for all parameters for the current day and previous six days
- Display 24-hour trend graphs for all the parameters
- Display weather data in metric or English units

The display unit incorporates a screen saver that turns off the backlight to the LCD screen by the touch of a button. The backlight is turned is turned back on by touching any part of the screen.

The Weather Display is offered in three formats:

1. Desktop chassis also suitable for wall mounting, (8.9" W x 6.3" H x 1.87" D)
2. Panel mount, (8" W x 5.4" H x 1.55" D)
3. 19" rack mount, (19" x 6.7")

Physical Description

Desktop Chassis

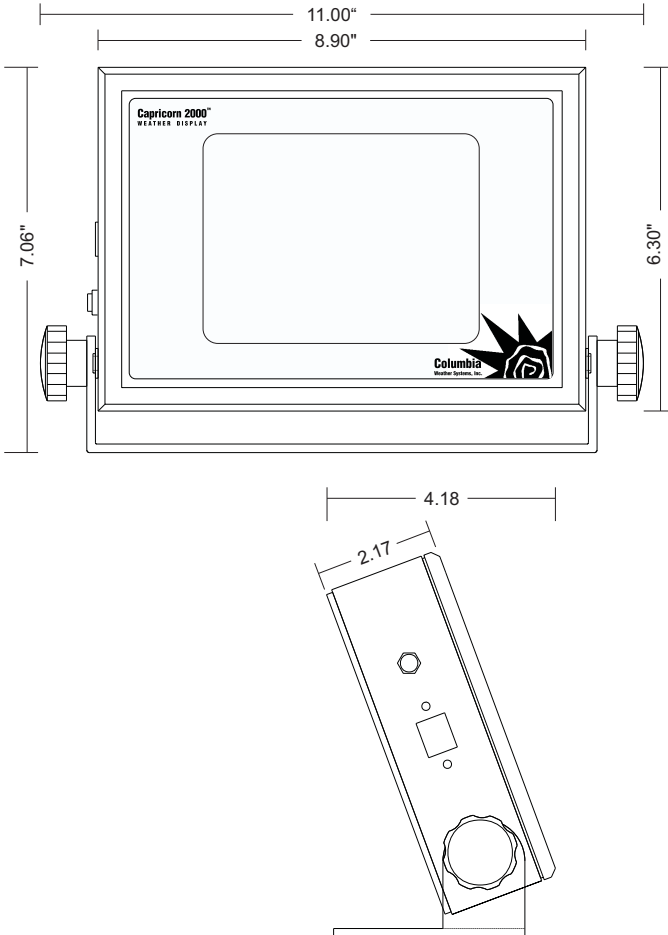

The Weather Display in the desktop chassis configuration comes with the following:

1. Weather Display chassis and base
2. Wall-mount power supply
3. RS-232 cable to the Control Module
4. User manual

19" Rack Mount

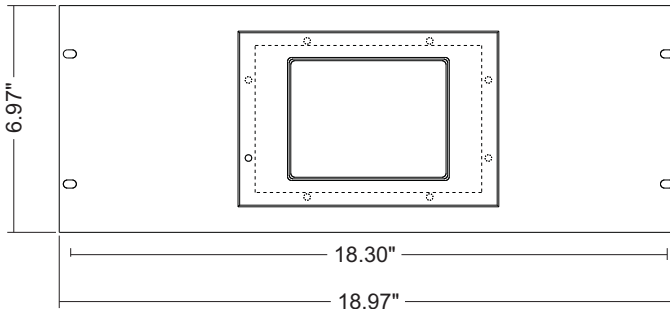

The Weather Display in the 19" rack mount configuration comes with the following:

1. Weather Display mounted on a 4U 19" rack mount panel including mounting hardware
2. Wall-mount power supply
3. RS-232 cable to the Control Module
4. User manual

Installation

Location Considerations

Since the Weather Display employs an LCD screen, the viewing angle and glare caused by light reflections must be considered when choosing a location. Install the Weather Display at a height and angle that makes it easy for the user to see and touch the screen.

Base Installation

The Weather Display base has four holes for permanent installation.

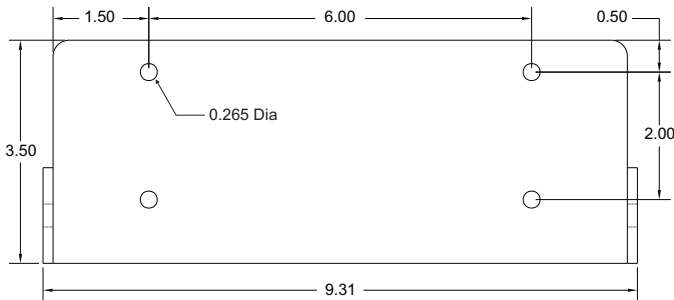

The base is designed to hold the chassis on a desktop or any other flat surface at various tilt angles.

The base also has four mounting holes to secure it to any surface including a wall.

To secure the base:

1. Remove the chassis from the base by removing both side knobs. Be sure not to drop or lose the white shoulder washers.
2. Mark the location of the four holes on the mounting surface.
3. Drill four holes using the appropriate size drill bit based on the size of screws being used.
4. Secure the mounting base using four screws.
5. Reattach the chassis using the two side knobs. Make sure that the shoulder washers are in place.

Power Connection

The Weather Display is shipped with the following power supply:

Input: 100V to 240V AC, 50/60 Hz, 0.7 Amp

Output: 24 V DC, 1.00 Amp

The Weather Display requires a minimum of 12 V DC / 1.6 Amp or 24 V DC / 0.8 Amp power. The high current requirement is for the LCD screen surge current when the unit is first turned on. Otherwise, the Weather Display at 24 volts consumes about 4.5 Watts with the backlight on and 1.5 Watts with the backlight off.

RS-232 Connection

The Weather Display is shipped with a standard 7-foot RS-232 cable. This cable can be factory configured up to 150 feet in length and has two RJ-11 connectors.

The RS-232 range also can be extended by using an RS-422 converters or wireless transceivers which eliminates the cable between the Weather Display and the weather station.

Capricorn 2000/2000EX, Direct RS-232

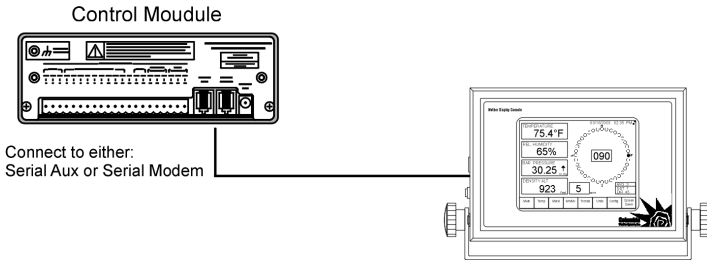

Pegasus/Wireless

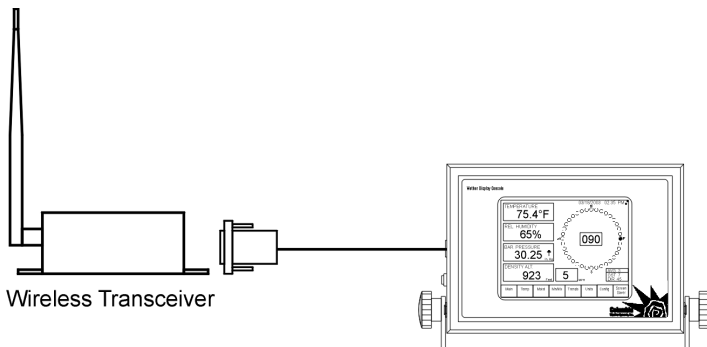

Orion Weather Station, Direct RS-232

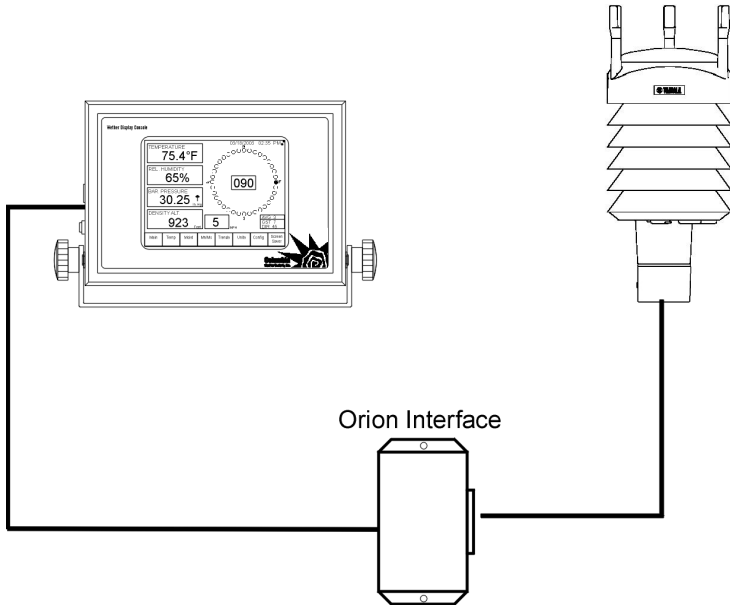

Orion LX Weather Station, Direct RS-232

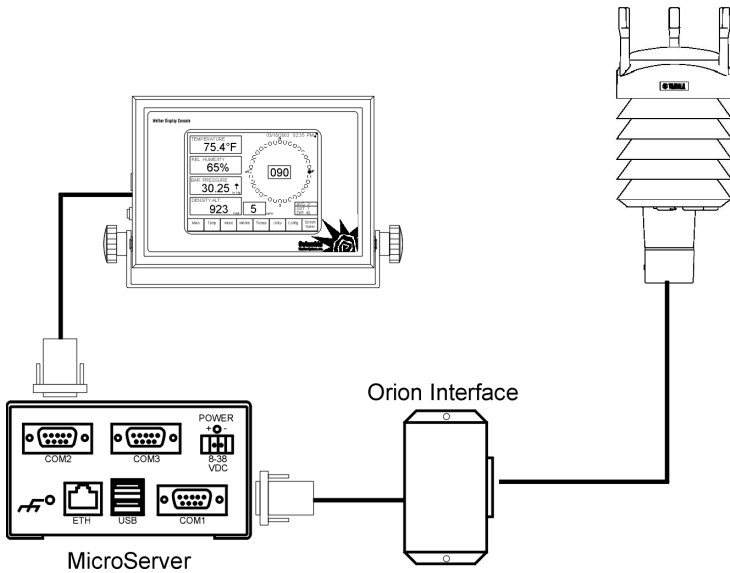

Angle Adjustment

To adjust the angle of the desktop chassis:

1. Loosen only one knob while holding the chassis with the other hand (otherwise the chassis might drop).
2. Loosen the second knob while holding the chassis with the other hand.
3. Change the angle of the chassis.
4. Tighten both knobs.

Contrast Adjustment

The contrast of the LCD screen can be adjusted in the Config. screen. Please refer to Config. Screen - Operation section for more details.

Note: The back light for the LCD screen takes two to three minutes to come up to full intensity after power up.

The internal contrast adjustment screw located on the back of the display is disabled.

Panel Mount Installation

Panel Cutout:

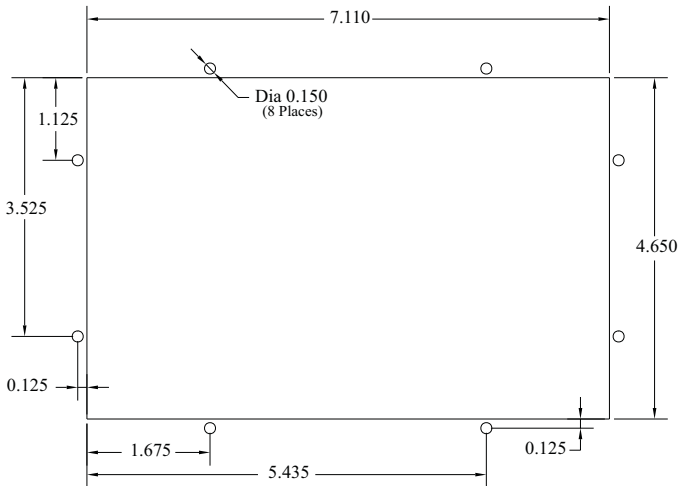

A bezel and a gasket are included with the Panel Mount Weather Display.

Follow these steps for panel-mount installation:

1. Machine an opening in the panel in accordance with the dimensions shown in the drawing above.
2. Drill eight holes, 0.15" diameter, in the locations shown in the drawing above.
3. Carefully "drop in" the Weather Display with the bezel and gasket attached.
4. Fasten the unit with the eight 4-40 hex nuts supplied.

Rack Mount Installation

The rack mount version of the Weather Display can be installed in a 19" rack mount chassis and will occupy a 4U slot. Mounting hardware is supplied with the unit.

Operation

Initialization

Connect the Weather Display to the weather station using the RS-232 cable, RS-422 cable/converter, or the wireless transceivers.

The weather station should be installed with all the sensors connected and power applied. Please refer to the Weather Station user manual for more information about installation.

Apply power to the Weather Display. Be sure to use the power supply provided with the unit.

The Weather Display will load the Main monitoring screen.

If this is the first time the unit is powered:

1. The screen will not display any numbers until it receives the first transmission from the weather station. This process can take up to 25 seconds.
2. In the Units screen select the desired units and the installed sensors.
3. Select the Config. Screen. Select the DATE/TIME button and confirm that the date and time are correct. Reset it if necessary.
4. In the main Config Screen adjust the screen contrast. Note that the backlight for the LCD screen takes two to three minutes to come up to full intensity.
5. In the main Config Screen, select the ADVANCED button and set the Rain/Density Altitude choice for the Main screen, Relative Humidity/Dew Point choice for the Main screen and the Wind Direction Resolution (available only for Orion, Capricorn 2000EX and Pegasus EX models).

Main Screen

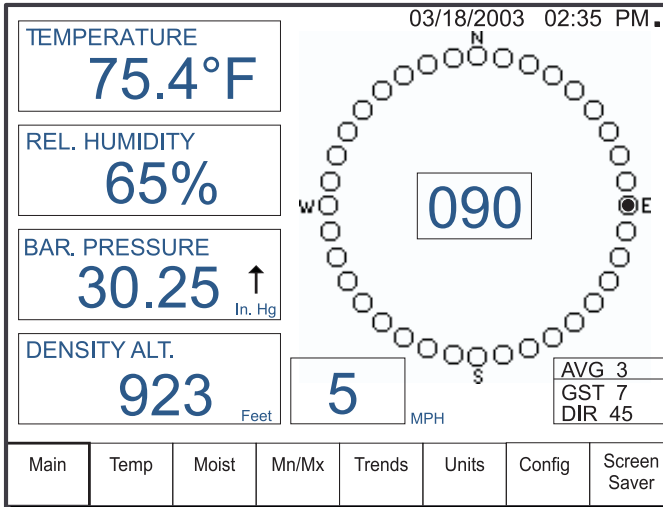

Date and Time

Are displayed in the upper right side of the main screen and all other screens.

Temperature

Displays the temperature reading from the first temperature probe connected to the Control Module. The value can be displayed in degrees Fahrenheit or Celsius.

The temperature reading is updated every 15 seconds.

Please note that the air temperature reading is accurate only when the temperature probe is located in the shade. This can be done by placing the probe at the north facing side of a building or by using an aspirating radiation shield.

Relative Humidity/Dew Point

Displays the relative humidity in percentage or dew point in degrees Fahrenheit or Celsius depending on the user configuration in the Config. Screen. Readings are updated every 15 seconds.

Barometric Pressure

Displays the barometric pressure reading. The value can be displayed in inches of mercury (in. Hg.), millibars (mbar) or kilopascals (Kpa).

The barometric pressure reading is updated every 15 seconds.

The barometric pressure reading is affected by the pressure offset and elevation settings in the Config. Screen.

Barometric Pressure Trend

A barometric pressure trend indicator is displayed to the right of the pressure reading. When the unit is first powered, the indicator will be absent. The Weather Display requires two hours of operation before it displays the pressure trend. The pressure trend is determined by comparing the pressure average for the past hour to the pressure average of the previous hour.

If the difference is less than or equal to 0.01 In. Hg. the trend is steady and is shown as “ – ”.

If the difference is greater than +0.01 in. Hg. the trend is increasing and is shown as “ ↑ ”.

If the difference is less than -0.01 in. Hg. the trend is decreasing and is shown as “ ↓ ”.

Rain for the Day

Note: In Configuration/Advanced Settings, the user can choose to display the rain for the day or density altitude in this area.

Displays the rainfall reading for the day. The value can be displayed in inches or millimeters.

The rainfall reading is reset to zero at midnight.

The rain for the day reading is updated every 15 seconds.

Density Altitude

Note: In Configuration/Advanced Settings, the user can choose to display the rain for the day or density altitude in this area.

Displays the density altitude. The value can be displayed in feet or meters.

The density altitude calculation is based on temperature, relative humidity, barometric pressure and elevation.

Density altitude reading is updated every 15 seconds.

Wind Speed

Displays wind speed-reading. The value can be displayed in miles per hour (MPH), kilometers per hour (KPH), knots or meters per seconds.

The wind speed-reading is updated every second.

The wind speed average is displayed and is updated every second. In Config/Advanced Settings, the wind speed average can be set for 1, 2, 5, 10, 15, 30 or 60 minutes.

The wind speed and direction gust is displayed and is updated every second. In Config/Advanced Settings, the wind speed gust can be set for the last 5, 10, 15, 30 or 60 minutes.

To view the wind gust for the day, go to the Mn/Mx screen.

The wind gust reading will be reset to zero at midnight.

Wind Direction

Displays the wind direction reading graphically on a 16 point (Capricorn 2000 and Pegasus models) or 36 point (Orion, Capricorn 2000EX, and Pegasus EX models) compass rosette and in degrees.

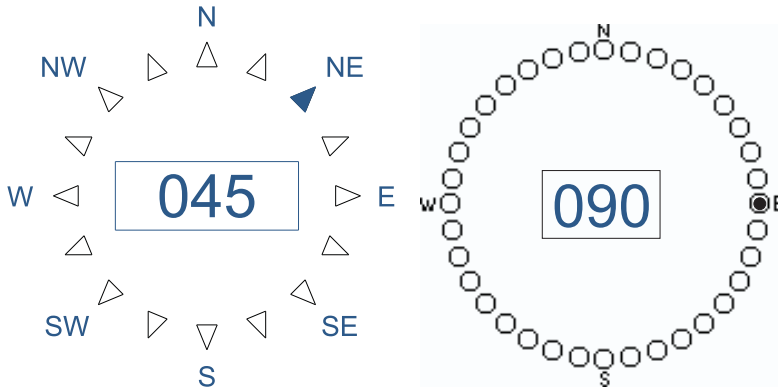

For the 36 point compass rosette, the numerical wind direction readout can be set in the Config./Advanced Settings screen to display the maximum resolution or restrict the resolution to 10-degree increments.

The wind direction reading indicates the direction from which the wind is coming. For example, if the Weather Display is reading E (45°), the wind is coming from the east (easterly wind) and heading to the west.

The wind direction reading is updated every second.

Temperature (Temp) Screen

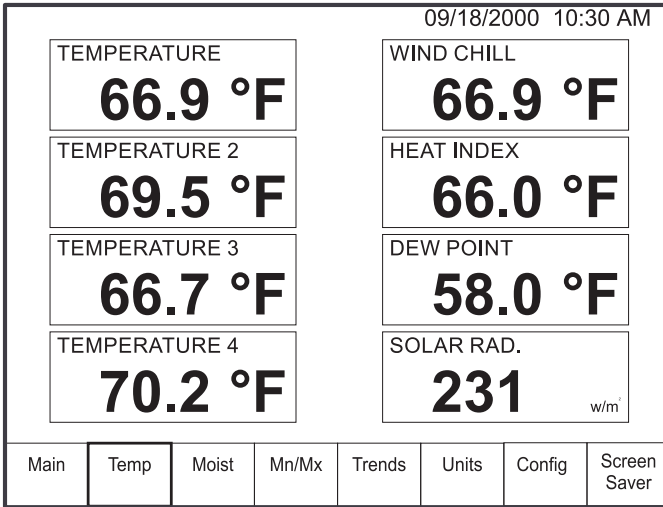

Temperature

Displays the temperature reading from the first temperature probe connected to the Control Module. The value can be displayed in degrees Fahrenheit or Celsius.

The temperature reading is updated every 15 seconds.

Please note that the air temperature reading is accurate only when the temperature probe is located in the shade at all times. This can be done by placing the probe at the north facing side of a building or by using an aspirating radiation shield.

This temperature reading is repeated in the Main Screen.

Temperature 2 through 4

(Only available with the Capricorn and Pegasus stations.)

Displays the temperature reading from the second, third and fourth temperature probes connected to the Control Module respectively. The values can be displayed in degrees Fahrenheit or Celsius.

The temperature reading is updated every 15 seconds.

These temperature sensor channels can be used for indoor air, soil, and outdoor air at various elevations, water (lake or stream) and other applications.

Wind Chill

Displays the wind chill temperature derived from the first temperature sensor connected to the Control Module and the one-minute average wind speed. The value can be displayed in degrees Fahrenheit or Celsius.

Note: *Wind chill Temperature is only defined for temperatures at or below 50 degrees F and wind speeds above 3 mph.*

The wind chill reading is updated every 15 seconds.

Heat Index

Displays the heat index temperature derived from the first temperature sensor connected to the Control Module and the relative humidity sensor. The value can be displayed in degrees Fahrenheit or Celsius.

Heat Index temperature equals real air temperature when real air temperature is less than 70 °F.

The heat index reading is updated every 15 seconds.

Dew Point/Humidity

Displays dew point in degrees (Fahrenheit or Celsius) or the relative humidity in percentage depending on the user configuration in the Config. Screen. Readings are updated every 15 seconds.

Dew point temperature is derived from the first temperature sensor connected to the Control Module and the relative humidity sensor. The value can be displayed in degrees Fahrenheit or Celsius.

The dew point reading is updated every 15 seconds.

Channel X1

(Only available with the Capricorn and Pegasus stations.)

Displays the reading from any sensor connected to the X1 multipurpose channel on the Control Module.

This channel is usually used by the solar radiation sensor. This value is displayed in watts per meter squared (W/m^2).

This channel can be customized at the factory to accommodate other sensors.

Channel X1's reading is updated every 15 seconds.

Moisture (Moist) Screen

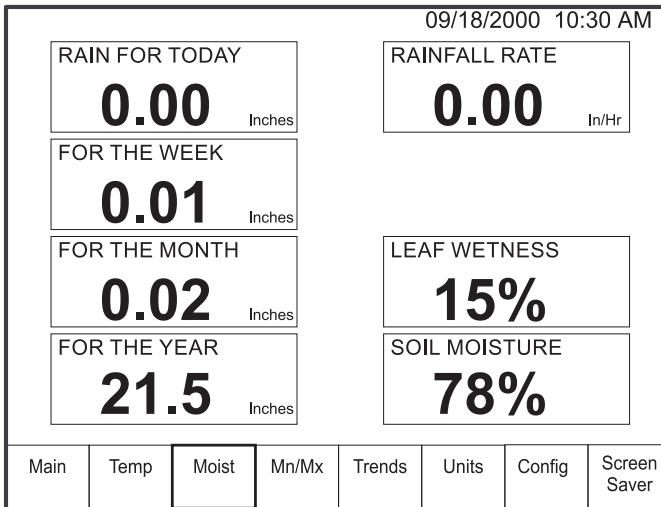

Rain for the Day

Displays the rainfall reading for the day. The value can be displayed in inches or millimeters.

The rainfall reading is reset to zero at midnight.

The rain for the day reading is updated every 15 seconds.

Rain for the Week

Displays the rainfall accumulation for the week. This reading is reset to zero at the beginning of the week. This value can be displayed in inches or millimeters.

Rain for the week is updated every 15 seconds.

Rain for the Month

Displays the rainfall accumulation for the month. This reading is reset to zero at the beginning of the month. This value can be displayed in inches or millimeters and is reset at the beginning of each month.

Rain for the month is updated every 15 seconds.

Rain for the Year

Displays the rainfall accumulation for the year. This reading is reset to zero at the beginning of the year (00:00 January 1).

Rain for the year is displayed in inches or millimeters to the nearest tenth of an inch and is updated every 15 seconds.

Rainfall Rate

Displays the rainfall rate based on the rainfall for the last 5 minutes. This value can be displayed in inches per hour or millimeter per hour.

The rainfall rate is updated every 15 seconds.

Leaf Wetness

(Only available with the Capricorn and Pegasus stations.)

Displays the leaf (or surface) wetness. The value is displayed in percentage of wetness. Close to 0% is dry and close to 100% is wet.

The leaf wetness reading is updated every 15 seconds.

Channel X2

(Only available with the Capricorn and Pegasus stations.)

Note: Channel X2 is dedicated to the wind direction sensor in the EX models.

Displays the reading from any sensor connected to the X2 multipurpose channel on the Control Module.

This channel is usually used by the soil moisture sensor. This value is displayed in percentage of moisture.

This channel can be customized at the factory to accommodate other sensors.

Channel X2's reading is updated every 15 seconds.

Min/Max Screen

		09/18/2000 10:30 AM			
		09/17			
		Min		Max	
TEMPERATURE 1	50.7	7:01 AM	82.9	02:38 PM	
WIND CHILL	50.7	7:01 AM	82.9	02:38 PM	
HEAT INDEX	50.0	6:09 AM	81.0	02:38 PM	
DEW POINT	45.7	6:29 AM	58.1	12:23 PM	
WIND SPEED	0	00:00 AM	8	02:41 PM	
REL. HUMIDITY	35	5:35 PM	87	05:40 AM	
BAR. PRESSURE	30.13	5:43 PM	30.25	09:40 AM	
RAIN FOR THE DAY	0.00	00:00 AM	0.00	00:00 AM	
LEAF WETNESS	15	12:11 PM	75	03:06 AM	
SOLAR RADIATION	0	00:00 AM	1040	11:40 AM	
SOIL MOISTURE	70	3:30 PM	75	8:25 AM	
TEMPERATURE 2	47.0	6:35 PM	81.5	02:26 PM	
TEMPERATURE 3	46.3	5:39 PM	77.6	02:26 PM	
TEMPERATURE 4	67.4	6:50 AM	71.4	03:52 PM	

Main	Temp	Moist	Mn/Mx	Trends	Units	Config	Screen Saver
------	------	-------	-------	--------	-------	--------	--------------

The Min/Max screen displays the minimum and maximum values and time of occurrence for all the parameters for the day. The values are displayed in the units defined in the Units screen.

The Weather Display stores the min/max values for the current day and the previous six days.

To view previous days, simply touch the LEFT button. To view the next day, touch the RIGHT button. To go to the current day, touch the Mn/Mx button.

Note that Leaf Wetness, Solar Radiation, Soil Moisture, and Temperature 2 through 4 are only available on the Capricorn and Pegasus stations.

Trends Screen

09/18/2000 10:30 AM

TEMPERATURE 1	HEAT INDEX	BAR. PRESSURE
TEMPERATURE 2	WIND CHILL	RAINFALL
TEMPERATURE 3	HUMIDITY	LEAF WETNESS
TEMPERATURE 4	WIND SPEED	SOLAR RAD.
DEW POINT	WIND DIR	SOIL MOISTURE

Main	Temp	Moist	Mn/Mx	Trends	Units	Config	Screen Saver
------	------	-------	-------	--------	-------	--------	--------------

To display the trend of a parameter, select the desired parameter by touching it on the screen. The Weather Display will display the 24-hour trend graph for that parameter.

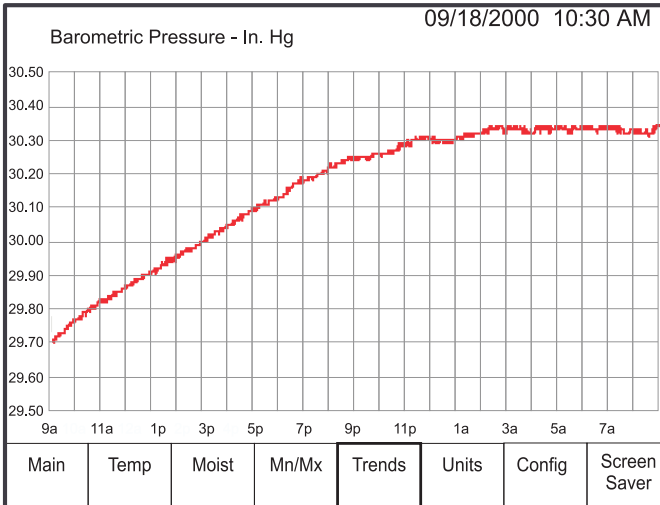

To go back to the main Trends screen, touch the Trends button.

The Weather Display stores a value for each parameter every five minutes. In 24-hours the unit will have 288 data points for each parameter.

Since the Weather Display does not store or display every value in the 24-hr period, it may miss some peak values in all parameters except wind speed where peak wind is displayed.

Parameters that are not selected in the Units screen will have a dotted box around them (compared to the solid box around selected parameters) and will not be active.

Note that Leaf Wetness, Solar Radiation, Soil Moisture, and Temperature 2 through 4 are only available on the Capricorn and Pegasus stations.

Units Screen

09/18/2000 10:30 AM							
Units/Sensors							
TEMPERATURE:		°F	°C				
WIND SPEED:		MPH	KPH	m/s	Knots		
PRESSURE:		In.Hg	mbar	Kpa			
RAIN FALL:		Inches	mm				
INSTALLED SENSORS:		T1	T2	T3	T4	RH	
		Rain	LW	X1	X2		
Main	Temp	Moist	Mn/Mx	Trends	Units	Config	Screen Saver

This screen allows the viewing and changing of parameter units and the selection of installed sensors.

To change the units for a parameter, simply touch the desired unit and it will be highlighted with a box.

The change will take effect in all the areas where the parameter value is displayed, including in Trends and Min/Max.

Relative humidity and leaf wetness are always displayed in percentage.

The multi-purpose channels X1 and X2 are factory set to match the sensor and customer desired units.

Note: The Installed Sensors selections are only available for the Capricorn and Pegasus stations.

To define the installed sensors in the weather station system, simply select these sensors. The installed sensors will be highlighted with a box. The Weather Display will not show values for the sensors that are not installed in any of the screens including the Max/Min screen. The trend chart also is not available for these sensors.

Config. Screen

03/18/2003 02:35 PM							
CONFIGURATION						DATE/TIME	
Contrast: 43	◀		▶		CALIBRATION		
Beeper On:	<input checked="" type="checkbox"/>		ADVANCED				
Wind Dir. Offset:	0						
Capricorn 2000 Weather Display V2.03 © 2000, Columbia Weather Systems, Inc.							
Main	Temp	Moist	Mn/Mx	Trends	Units	Config	Screen Saver

Contrast

To adjust the contrast level, use the left and right arrow buttons to decrease or increase the contrast. Please allow the screen to warm up for about five minutes before adjusting the contrast.

The contrast is set to a default value of 43 at the factory.

Beeper

The touch screen beeper is on by default. To turn the beeper off or on, touch the check-box.

Select Done to return to the Config screen.

Wind Direction Offset

Allows the user to enter a degree offset to change the wind direction value. This feature is useful for vehicle or boat mounted systems. The offset is added to the actual wind direction value. For example, if the sensor output is 45° and the offset is 10°, then the console will display 55° for the wind direction value.

To change the wind direction offset value, touch the value field and enter the new value using the keypad screen.

For Orion stations, the Wind Direction Offset is located in the Offsets screen.

Date/Time

To set the date and time, touch the Date/Time box in the Config Screen. Use the left and right arrow buttons to move the pointer to the desired date/time field and use the “-“ and “+” buttons to decrease or increase the value. Touch the Enter button when done. The date and time will then be updated in the Weather Display unit and in the Control Module.

Touch the Cancel button to exit the screen without any changes.

Calibration/Offsets

(Capricorn and Pegasus Only)

03/18/2003 02:35 PM							
Configuration							
T1 OFFSET:	202		PRESSURE OFFSET:	79			
T2 OFFSET:	295		ALTITUDE:	220			
T3 OFFSET:	125		RAIN OFFSET:	0.05			
T4 OFFSET:	-158						Done
Main	Temp	Moist	Mn/Mx	Trends	Units	Config	Screen Saver

Capricorn and Pegasus Stations

From the Config Screen touch the CALIBRATION or the Offset button.

In the Capricorn and Pegasus stations, once this screen is selected, the system will stop the automatic weather data output and will read the configuration values from the Control Module. The automatic weather data output will then be resumed. Every time a configuration value is changed, the new value is written back to the Control Module (with the exception of the Rain Offset which is stored in the Weather Display.)

In the Orion stations, the offset values are stored in the Weather Display.

Temperature Offsets

Temperature offsets are calibration values entered at the factory based on the temperature probes sent with the system.

If a new or replacement temperature probe is installed, the user will need to enter the new offset provided from the factory.

To enter a temperature offset, touch the desired temperature offset box. Enter the temperature offset that comes with the temperature probe and touch the Enter button.

Temperature offsets should be entered in °F x 100. For example, 0.5 °F offset is entered as 50.

Pressure Offset

Pressure offsets are entered at the factory to calibrate the pressure sensor.

To enter a pressure offset, touch the pressure offset box. Enter the pressure offset and touch the Enter button.

The pressure offset is entered in in.Hg x 100. For example, 0.03 in Hg offset is entered as 3.

Please refer to the Weather Station User Manual for more information.

Altitude

The Weather Display is set to a default altitude of 0 feet.

The local altitude of the station should be entered in order to get the correct barometric pressure reading.

To enter the altitude, touch the altitude box. Enter the altitude in feet and touch the Enter button.

Rain Offset

To correct the rain accumulation for the year, enter a rain offset. The rain offset can be positive (adding to the rain for the year) or negative (subtracting from the rain for the year).

The rain offset will be cleared (set to zero) at the start of a new year.

Keypad

09/18/2000 10:30 AM									
PRESSURE OFFSET:		1			2		3		
		4			5		6		
79_____		7			8		9		
		-			0		C		
		Cancel			Enter				
Main	Temp	Moist	Mn/Mx	Trends	Units	Config	Screen Saver		

The keypad screen appears every time the user is asked to enter or change a numeric value.

The keypad screen will normally open with the current configuration value filled in the text box.

Use the "C" button to clear the entered value.

Use the "-" button to enter a minus sign.

Use the "Cancel" button to exit the keypad screen without effecting any change.

Use the "Enter" button to accept the changes and exit the screen. The "Enter" button will cause the Weather Display to write the new value to the Control Module.

Advanced Settings

03/18/2003 02:35 PM

ADVANCED SETTINGS

Time Intervals (Minutes)

Wind Gust: 5

Wind Average: 1

Readout Option: Density Altitude Rain

Rel. Humidity: Main Page Temp. Page

Wind Dir Res: 10 Degrees Maximum Resolution

Done

Main	Temp	Moist	Mn/Mx	Trends	Units	Config	Screen Saver
------	------	-------	-------	--------	-------	--------	--------------

From the Config Screen touch the ADVANCED button.

Wind Gust:

To change the wind gust interval, use the left and right arrow buttons to decrease or increase the number of minutes. The wind gust intervals are limited to 5, 10, 15, 30 and 60 minutes.

Wind Average:

To change the wind average interval, use the left and right arrow buttons to decrease or increase the number of minutes. The wind average intervals are limited to 1, 2, 5, 10, 15, 30 and 60 minutes.

Readout Option:

Select Density Altitude or Rain to display in the Main Screen.

Relative Humidity:

Select Relative Humidity or Dew Point to display in the Main Screen. The other value will display in the Temp Screen

Wind Dir Res:

Note: Only available with Capricorn 2000EX, Pegasus EX and Orion Stations. The Capricorn 2000 and Pegasus stations have a set 22.5 degree wind resolution.

Select wind direction resolution to be displayed numerically. 10 Degrees selection will restrict the readout to 10-degree increments. The Maximum Resolution selection will display the maximum resolution available from the Control Module.

Select Done to return to the Config Screen.

Screen Saver

The Weather Display uses an LCD screen with a backlight. To preserve the backlight life a screen saver feature is incorporated.

The screen saver button will simply turn off the backlight. The Weather Display is still fully operational.

The backlight is a replaceable dual cold-cathode fluorescent tube rated at 20,000 hours to 30,000 hours (2.28 to 3.42 years of continuous operation).

To turn the backlight on, simply touch any part of the screen.

Maintenance

The Weather Display requires no maintenance except for cleaning the chassis and the LCD touch screen.

To clean the LCD touch screen, turn the unit off, spray a clean cloth with a glass cleanser (do not spray the screen directly) and clean the screen.

Troubleshooting

Communication Indicator

The communication indicator is a dot to the right of the date/time in every screen.

If the dot is blinking, the Weather Display is receiving data from the weather station.

If the dot is constantly on or off, the Weather Display is not receiving data from the weather station.

when selecting the Config Screen in the Capricorn and Pegasus station, the communication indicator will stop blinking while the information is being read from the Control Module. When finished the indicator will resume blinking.

In addition the Weather Display will blank out all current readings if the values are not being updated due to communication problems.

Incorrect Temperature Readings

In the Capricorn and Pegasus stations, if the temperature reading is around 255 °F or 123.9 °C, the temperature sensor is not installed or initialized in the Control Module.

Verify that the temperature sensor is installed. If it is, perform the temperature sensor initialization procedure. Please refer to the Weather Station User Manual for more information.

Trend Chart Not Updating

The time line axis in the trend charts will not update if there is no communication with the weather station. Once communication is reestablished, the time axis will catch up with current time and will fill in missing data with the last data value displayed.

Backlight Will Not Turn On

If the backlight does not come on, the unit should be returned to the factory for repair or backlight bulb replacement.

User Support Information

This section consists of the following items:

1. **Two-Year Limited Warranty:** Please read this document carefully.
2. **Return for Repair Procedure:** This procedure is for your convenience in the event you must return your Weather Display for repair or replacement. Follow the packing instructions carefully to protect your instrument in transit.

Limited Warranty

Columbia Weather Systems, Inc. (CWS), warrants the Weather Display to be free from defects in materials and/or workmanship when operated in accordance with the manufacturer's operating instructions, for two (2) years from date of purchase, subject to the provisions contained herein. CWS warranty shall extend to the original purchaser only and shall be limited to factory repair or replacement of defective parts.

Exclusions

Certain parts are not manufactured by CWS (i.e., certain purchased options, etc.) and are therefore not covered by this warranty. These parts may be covered by warranties issued by their respective manufacturers and although CWS will not warrant these parts, CWS will act as agent for the administration of any such independent warranties during the term of this warranty. This warranty does not cover normal maintenance, damage resulting from improper use or repair, or abuse by the operator. Damage caused by lightning or other electrical discharge is specifically excluded. This warranty extends only to repair or replacement, and shall in no event extend to consequential damages. In the event of operator repair or replacement, this warranty shall cover neither the advisability of the repair undertaken, nor the sufficiency of the repair itself.

THIS DOCUMENT REFLECTS THE ENTIRE AND EXCLUSIVE UNDERSTANDING OF THE PARTIES, AND EXCEPT AS OTHERWISE PROVIDED HEREIN, ALL OTHER WARRANTIES, EXPRESS OR IMPLIED, PARTICULARLY THE WARRANTIES OF MERCHANT ABILITY AND/OR FITNESS FOR A PARTICULAR PURPOSE ARE EXCLUDED.

This warranty gives you specific legal rights, and you may also have other rights, which vary from state to state.

Return for Repair Procedure

1. In the event of defects or damage to your unit, first call the factory Monday through Friday, 8:30 AM to 4:00 PM PST, (503) 629-0887 to determine the advisability of factory repair. The Service Department will issue an RMA number (Return Merchandise Authorization) to help us identify the package when received. Please place that number on the outside of the box.
2. In the event factory service is required, return your as follows:
 - A. Packing
 - ◆ Wrap the Weather Display in a plastic bag first.
 - ◆ Pack in original shipping carton or a sturdy oversized carton.
 - ◆ Use plenty of packing material.
 - B. Include:
 - ◆ A brief description of the problem with all known symptoms.
 - ◆ Your phone number.
 - ◆ Your return street shipping address (UPS will not deliver to a P.O. box.)
 - ◆ Write the RMA number on the outside of the box.
 - C. Shipping
 - ◆ Send freight prepaid. (UPS recommended.)
 - ◆ Insurance is recommended. (The factory can provide the current replacement value of the item being shipped for insurance purposes.)
 - D. Send to:

Columbia Weather Systems, Inc.
2240 NE Griffin Oaks Street, Suite 100
Hillsboro, Oregon 97124-6463
 - E. C.O.D. shipments will not be accepted.
3. If your unit is under warranty, after repair or replacement has been completed, it will be returned by a carrier and method chosen by Columbia Weather, Inc. to any destination within the continental U.S.A. If you desire some other specific form of conveyance or if you are located beyond these borders, then you must bear the additional cost of return shipment.
4. If your unit is not under warranty, we will call you with an estimate of the charges. If approved, your repaired unit will be returned after all charges, including parts, labor and return shipping and handling,

have been paid. If not approved, your unit will be returned as is via UPS COD for the amount of the UPS COD freight charges.

Reference

Glossary

Aspirating Radiation Shield

A device used to shield a sensor such as a temperature probe from direct and indirect radiation and rain while providing access for ventilation.

Barometric Pressure

The pressure exerted by the atmosphere as a consequence of gravitational attraction exerted upon the “column” of air lying directly above the point in question.

Celsius Temperature Scale

A temperature scale with the ice point at 0 degrees and the boiling point of water at 100 degrees.

Dew Point

The temperature to which a given parcel of air must be cooled at constant pressure and constant water-vapor content in order for saturation to occur. When this temperature is below 0°C, it is sometimes called the frost point.

Density Altitude

Density altitude is a meteorological variable that is important to pilots, especially during the summer. The density altitude is the altitude in a standard atmosphere where the density is the same as the given atmospheric density. During a hot muggy summer day, a pilot begins take off from an airport with an elevation of 2500 feet. Because of the warm temperature and the moisture in the air, the airplane has to work as if it was taking off at an airport at an elevation of 6000 feet resulting in the plane needing more power and a longer roll down the runway to take off.

Fahrenheit Temperature Scale

A temperature scale with the ice point at 32 degrees and the boiling point of water at 212 degrees.

Global Radiation

The total of direct solar radiation and diffused sky radiation received by a unit horizontal surface. Global radiation is measured by a pyranometer.

Heat Index

The heat index or apparent temperature is a measure of discomfort due to the combination of heat and high humidity. It was developed in 1979 and is based on studies of evaporative skin cooling for combinations of temperature and humidity.

Pyranometer

It measures the combined intensity of incoming direct solar radiation and diffused sky radiation. The pyranometer consists of a radiation-sensing element, which is mounted so that it views the entire sky.

Relative Humidity

Popularly called humidity. The ratio of the actual vapor pressure of the air to the saturation vapor pressure.

Sea Level Pressure

The atmospheric pressure at mean sea level, either directly measured or, most commonly, empirically determined from the observed station pressure.

In regions where the earth's surface pressure is above sea level, it is standard observational practice to reduce the observed surface pressure to the value that would exist at a point at sea level directly below.

Soil Moisture

Moisture in the soil within the zone of aeration present in the soil pores. In some cases this refers strictly to moisture within the root zone of plants.

Solar Radiation

The total electromagnetic radiation emitted by the sun. 99% of the sun's energy output falls within the wavelength interval from 0.15 microns to 4.0 microns, with peak intensity near 0.47 microns. About one-half of the total energy in the solar beam is contained within the visible spectrum from 0.4 to 0.7 microns, and most of the other half lies near infrared, a small additional portion lying in the ultraviolet.

Wind Chill

That part of the total cooling of a body caused by air motion.

Unit Conversion

Speed

Kilometers per hour = 1.610 x miles per hour

Knots = 0.869 x miles per hour

Meters per second = 0.448 x miles per hour

Feet per second = 1.467 x miles per hour

Temperature

Temperature in °C = 5/9 (temperature in °F - 32)

Temperature in °F = (1.8 x temperature in °C) + 32

Distance

Millimeters = 25.4 x inches

Pressure

Millibars = 33.86 x inches of mercury

Kilopascals = 3.386 x inches of mercury

Pounds per square inch = 0.49 x inches of mercury

Standard atmospheres = 0.0334 x inches of mercury

Solar Radiation

BTU/foot² minutes = 0.00529 x watts/meter²

Joules/centimeter² minutes = 0.006 x watts/meter²

Mega joules/meter² day = 11.574 x watts/meter²

Langley/minutes = 0.00143 x watts/meter²

Tables and Formulas

Wind Chill Chart

In 2001, NWS implemented an updated Wind chill Temperature (WCT) index. The change improves upon the former WCT Index used by the NWS and the Meteorological Services of Canada, which was based on the 1945 Siple and Passel Index.

In the fall of 2000, the Office of the Federal Coordinator for Meteorological Services and Supporting Research (OFCM) formed a group consisting of several Federal agencies, MSC, the academic community (Indiana University-Purdue University in Indianapolis (IUPUI), University of Delaware and University of Missouri), and the International Society of Biometeorology to evaluate and improve the windchill formula. The group, chaired by the NWS, is called the Joint Action Group for temperature Indices (JAG/TI). JAG/TI's goal is to upgrade and standardize the index for temperature extremes internationally (e.g. Wind chill Index).

The current formula uses advances in science, technology, and computer modeling to provide a more accurate, understandable, and useful formula for calculating the dangers from winter winds and freezing temperatures.

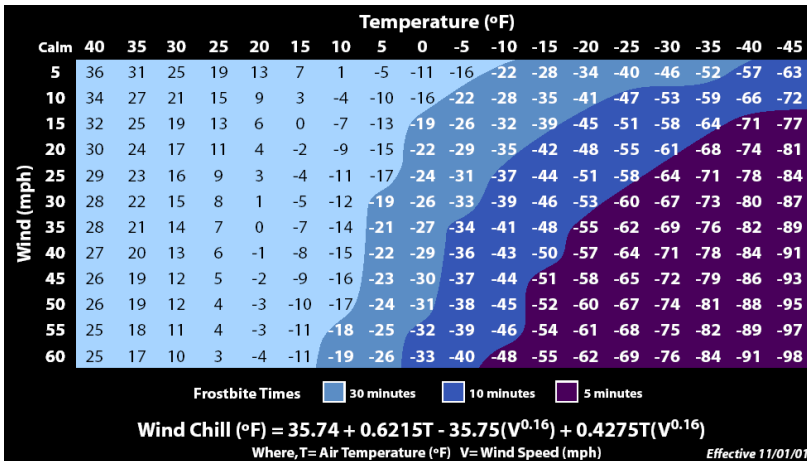

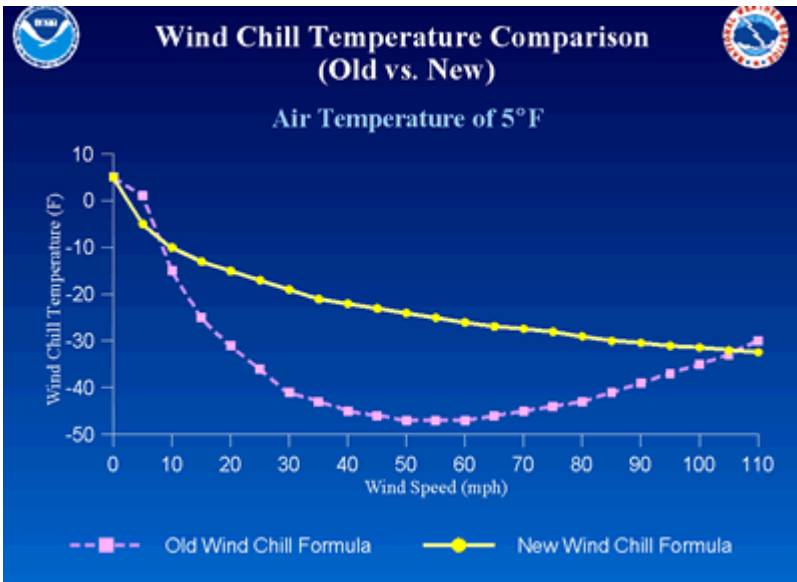

Wind Chill Equation

$$WC = 35.74 + 0.6215 T - 35.75(V^{0.16}) + 0.4275 T(V^{0.16})$$

Where:

WC = wind chill temperature in °F

V = wind velocity in mph

T = air temperature in °F

Note: Wind chill Temperature is only defined for temperatures at or below 50 degrees F and wind speeds above 3 mph.

Heat Index

RH	Temperature in °F													
	70	75	80	85	90	95	100	105	110	115	120	125	130	135
0	64	66	73	78	83	87	91	95	99	103	107	111	117	120
5	64	69	74	79	84	88	93	97	102	107	111	116	122	126
10	65	70	75	80	85	90	95	100	105	111	116	123	131	
15	65	71	76	81	86	91	97	102	108	115	123	131		
20	66	72	77	82	87	93	99	105	112	120	130	141		
25	66	72	77	83	88	94	101	109	117	127	139			
30	67	73	78	84	90	96	104	113	123	135	148			
35	67	73	79	85	91	98	107	118	130	143				
40	68	74	79	86	93	101	110	123	137	151				
45	68	74	80	87	95	104	115	129	143					
50	69	75	81	88	96	107	120	135	150					
55	69	75	81	89	98	110	126	142						
60	70	76	82	90	100	114	132	149						
65	70	76	83	91	102	119	138							
70	70	77	84	93	106	124	144							
75	70	77	85	95	109	130	150							
80	71	78	86	97	113	136								
85	71	78	87	99	117	140								
90	71	79	88	102	122	150								
95	71	79	89	105	126									
100	72	80	90	108	131									

Dew Point

$$B = (\ln (RH/100) + ((17.2694 * T) / (238.3 + T))) / 17.2694$$

$$\text{Dew Point in } ^\circ\text{C} = (238.3 * B) / (1 - B)$$

Where:

RH = Relative Humidity

T = Temperature in $^\circ\text{C}$

Ln = Natural logarithm



Columbia Weather Systems, Inc.
2240 NE Griffin Oaks Street, Suite 100
Hillsboro, OR 97124-6463

Telephone
(503) 629-0887

Fax
(503) 629-0898

Web Site
<http://www.columbiaweather.com>

Email
info@columbiaweather.com

Catalog Number: 81637
Version 3.11

Printed in U.S.A.